



Dynamic Motor Motion
Technology Corporation

AC Servo Motor

DHT Series

Specification Manual

Manual Version 1.2b

Oct 2013

Product Warranty

Products from DMM Technology Corp. are supported by the following warranty and return policies:

- 1-year warranty from the date of purchase or 14 months from the month of original date of shipment from factory.

Within the warranty period, DMM Technology Corp. will replace or repair any defective product free of charge given that DMM Technology Corp. is responsible for the cause of the defect. This warranty does not cover cases involving the following conditions:

- The product is used in an unsuitable or hazardous environment, resulting in damages to the product.
- The product is improperly handled resulting in physical damage to the product. Including falling, heavy impact, or shock.
- Damages resulting from transportation or shipping after the original factory delivery.
- Unauthorized alterations or modifications made to the product, resulting in damages to the product.
- The encoder has been modified or removed from the factory mounted position.
- Alterations have been made to the Name Plate of the product
- Damages resulting in usage of the product not specified by this manual.
- Damages to the product resulting from natural disasters
- Modifications have been made to the servo motor-end connectors (receptacle for 1.5kW and 2.0kW motors).

Within the 14-day return period, DMM Technology Corp. will refund the full amount of original factory product cost. This policy does not cover cases involving the following conditions:

- The product has been altered either cosmetically or electronically
- The product does not conform to the original factory manufactured standards
- Factory components included in the purchased package such as cables, software, or accessories of the product is missing.
- Alterations have been made to the Name Plate of the product.

DHT Series AC Servo Motor Features

- Factory mounted ABS-14-0 Absolute Encoder
- 14 bits (16,384 ppr) high resolution
- Medium Inertia – Industry leading performance
- Low cogging, extremely smooth operation
- Consistent, dynamic response
- Smooth S-curve - stability at both low and high speeds
- Patented transition technology between motion profiles
- Low and High voltage options
- Robust against shocks
- Low maintenance

Electromagnetic Brake Option

An optional Electromagnetic Brake can be added with any DHT-Series AC Servo motor. Contact DMM Technology Corp. for specifications and dimensions with the brake option.

Performance Overview

0.22kW – 0.75kW Output Capacity

		86-DHT-03	57-DHT-04E	60M-DHT-36	92M-DHT-72	
Applicable Servo Drive		DYN2-B	DYN2-H	DYN2-H	DYN2-H	DYN3-H
Rated Output Power	kW	0.22	0.3	0.4	0.75	
Instantaneous Max. Power	kW	0.55	0.75	0.9	0.9	1.8
Rated Torque	N•m	0.8	1	1.28	2.9	2.9
Instantaneous Max. Torque	N•m	2.1	3	3.6	7.2	7.2
Rated Voltage	V	60	60	60	150	150
Rated Current	Arms	3.46	4.72	6.28	4.71	4.71
Instantaneous Max. Current	Arms	20	20	20	20	20
Rated speed	rpm	3000	3000	3000	1000	3000
Max. Speed	rpm	3000	3000	3000	1080	6000
Rotor Moment of Inertia	kg•cm ²	0.65	0.5	0.7	2.05	2.05
Encoder		14-Bits Absolute (16,384 ppr)				
Shaft Diameter	mm	12.7	8.0	14.0	14.0	
Shaft Length	mm	25.0	22.0	30.0	45.0	
Flange	mm	85.8	56.3	60.0	92.0	
Bolt Circle	mm	98.4	66.75	70.0	105.0	
Motor Length (Body)	mm	91.0	135.0	140.0	194.0	
IP Rating		55	55	56	56	
Mass	kg	2.0	1.7	1.65	4.0	

1.5kW – 2.0kW Output Capacity

		31M-DHT-15	32M-DHT-28
Applicable Servo Drive		DYN3-T	DYN3-T
Rated Output Power	kW	1.5	2.0
Instantaneous Max. Power	kW	4.5	6.0
Rated Torque	N•m	5	9.5
Instantaneous Max. Torque	N•m	15	28
Rated Voltage	V	300VDC / 220VAC	300VDC / 220VAC
Rated Current	Arms	7.5	9.8
Instantaneous Max. Current	Arms	21	28
Rated speed	rpm	3000	2000
Max. Speed	rpm	3600	2400
Torque Constant	N•m/Arms	0.55	0.8
Rotor Inertia	kg•cm ²	12.0	19.3
Encoder		14-Bits Absolute (16,384 ppr)	
Shaft Diameter	mm	22.0	22.0
Shaft Length	mm	52.0	52.0
Flange	mm	130.0	130.0
Bolt Circle	mm	180.0	180.0
Motor Length (Body)	mm	163.0	196.0
IP Rating		56	56
Mass	kg	6.5	9.6

Motor External Dimensions

■ 32M-DHT-28 [Rated output: 2.0kW]

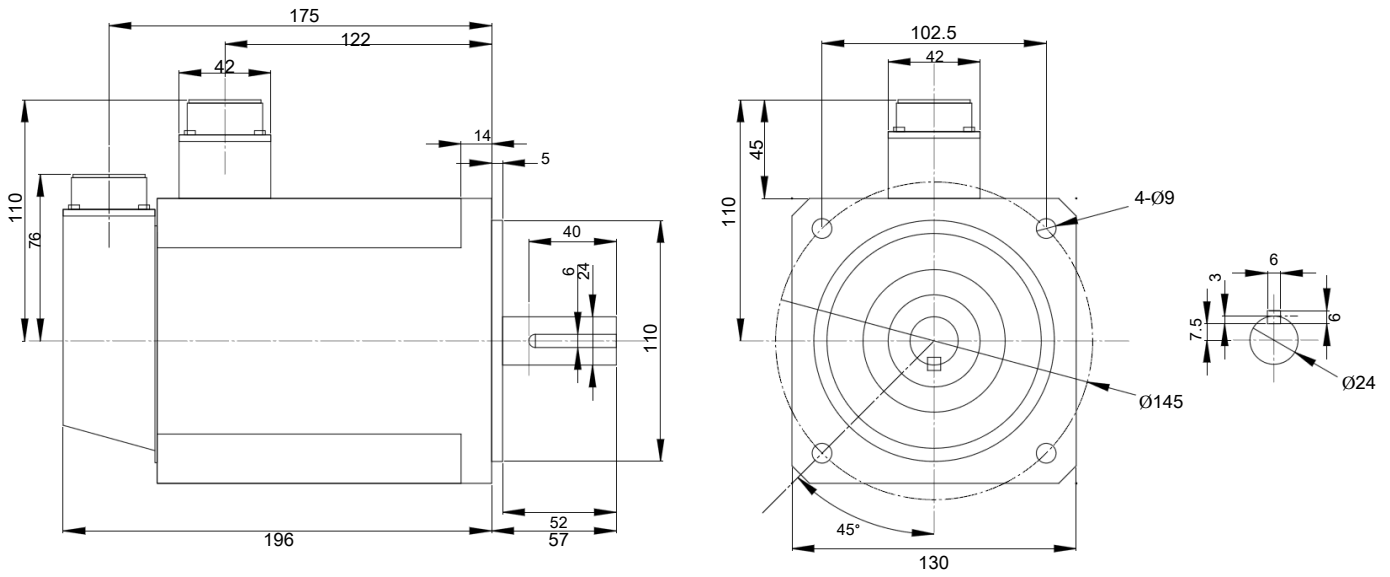

■ 31M-DHT-15 [Rated output: 1.5kW]

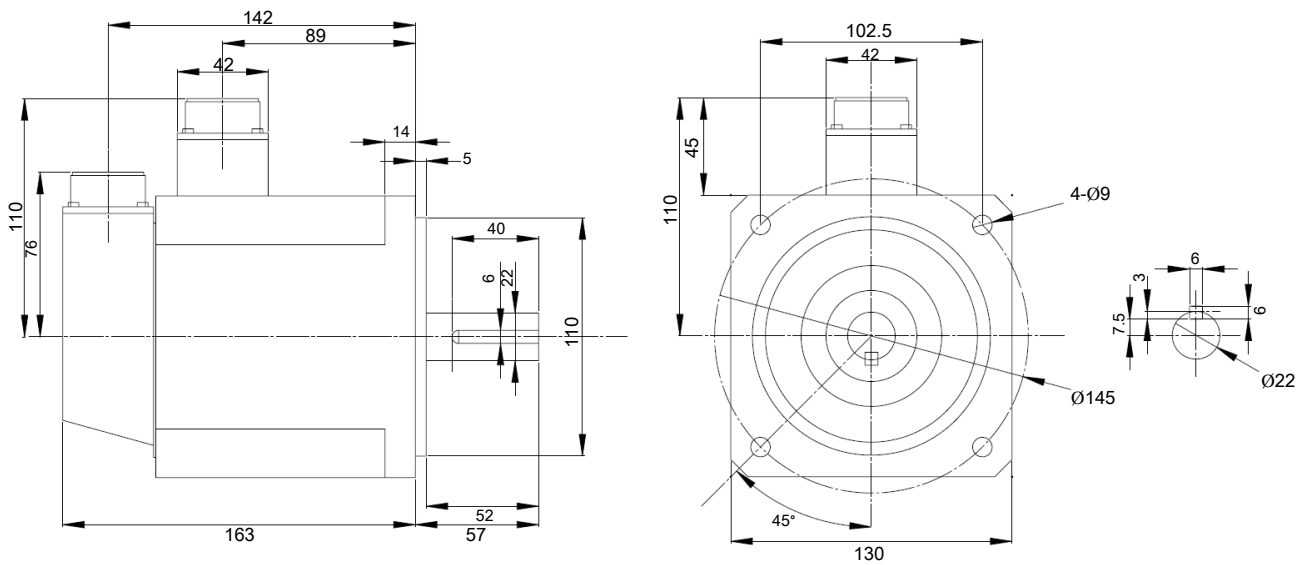

■ 92M-DHT-72 [Rated output: 0.75kW]

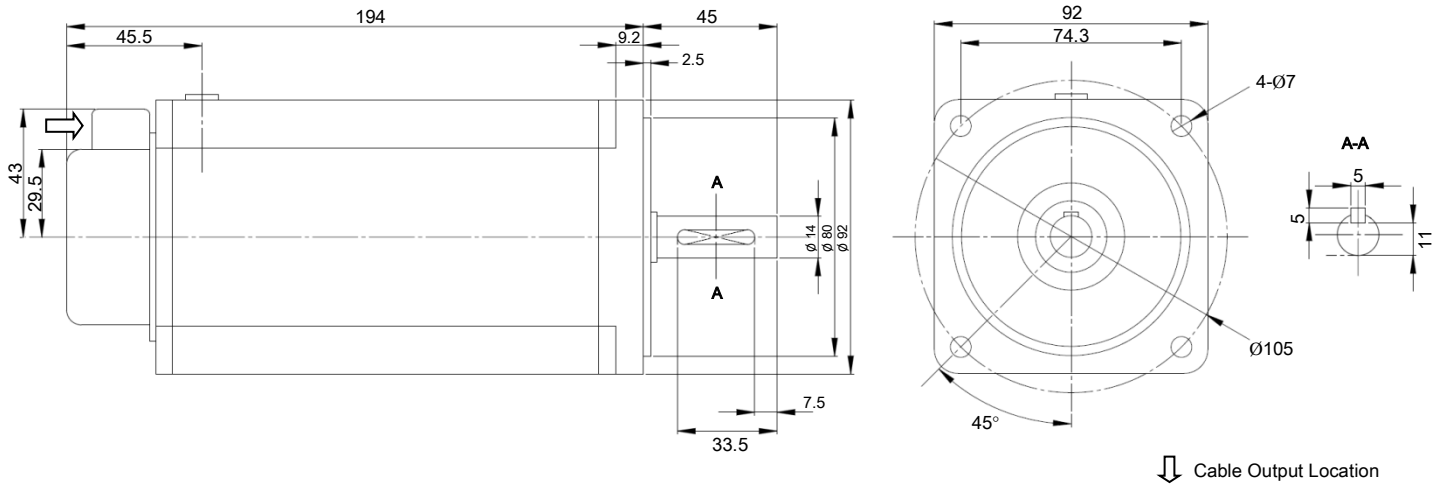

■ 60M-DHT-36 [Rated output: 0.4kW]

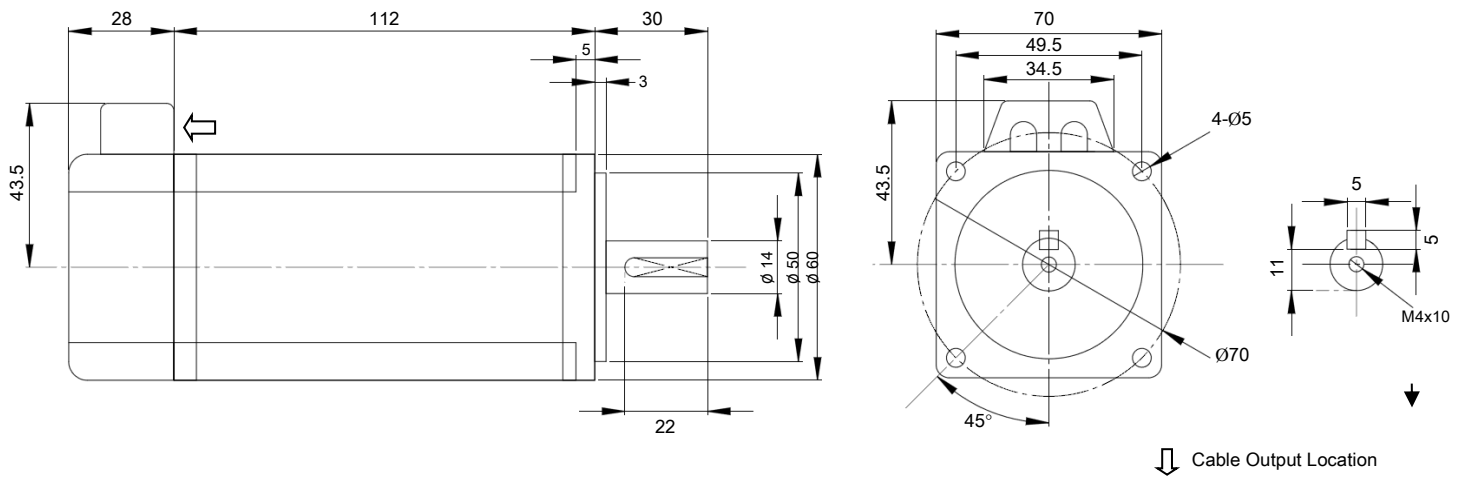

■ 57-HT-04E [Rated output: 0.3kW]

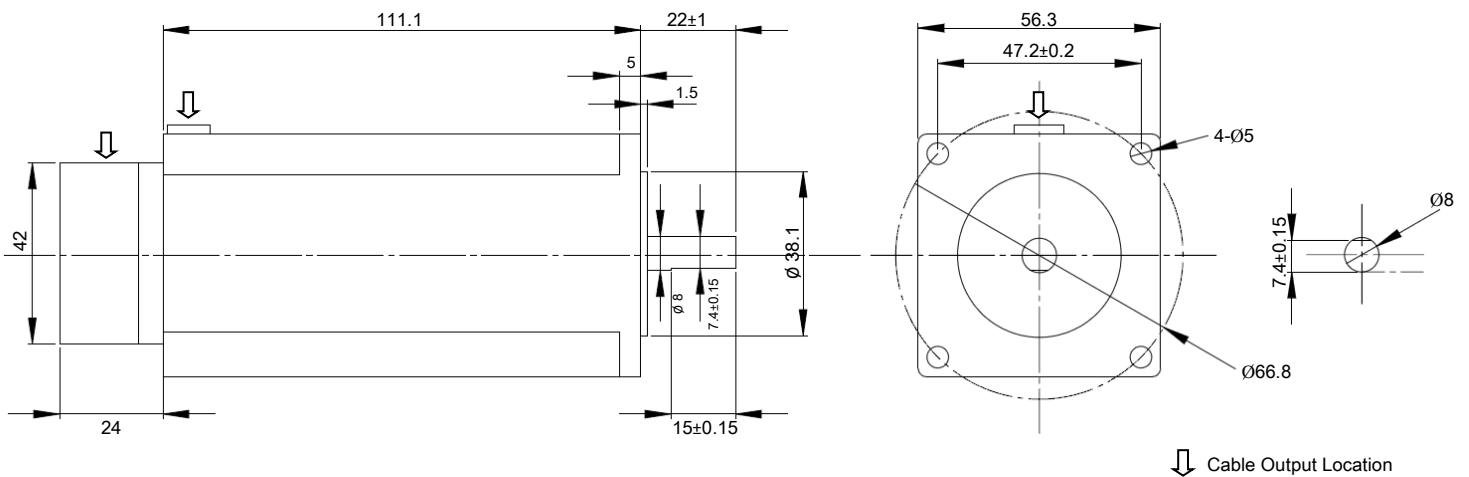

■ 86-DHT-03 [Rated output: 0.2kW]

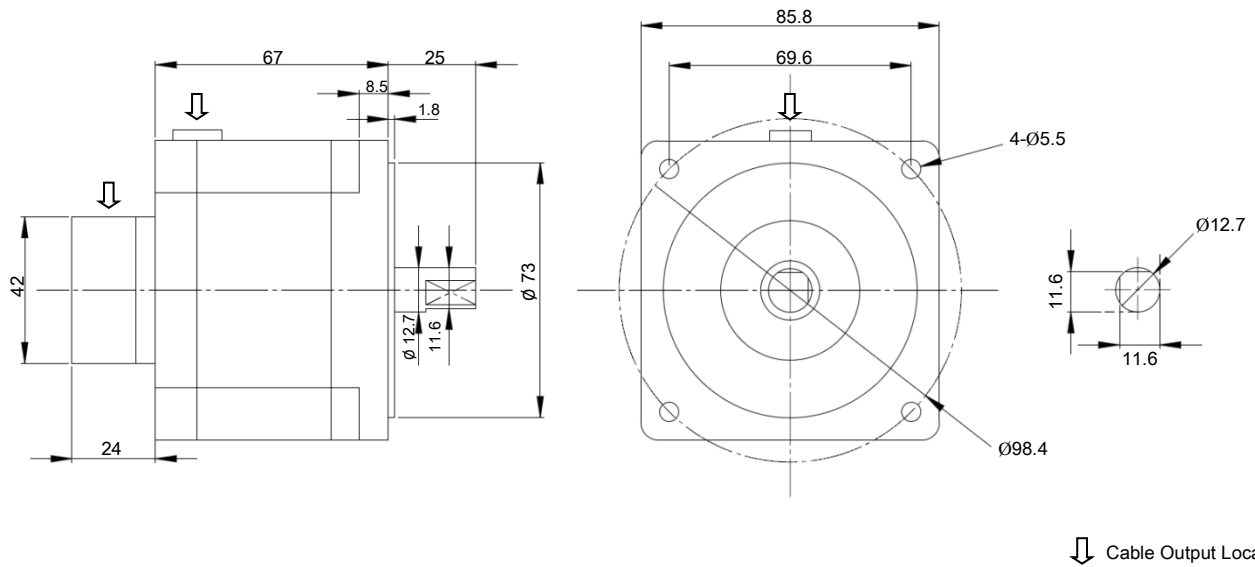

Motor Communication Layout

■ Encoder Feedback

Pin	Function
1	Serial data in for both UART and SPI, input-
2	Serial data in for both UART and SPI, input+
3	Clock signal for SPI input-
4	Clock signal for SPI input+
5	+5Vdc
6	NC
7	Serial data out for both UART and SPI, output-
8	Serial data out for both UART and SPI, output+
9	Gnd

■ Motor Power Cable Output

	86-DHT-03	57-DHT-04E	60M-DHT-36	92M-DHT-72
Phase A	Red	Yellow	Red	Red
Phase B	Yellow	Green	Blue	Blue
Phase C	Blue	Blue	Black	Black
FG	N/A	N/A	Yellow	Yellow

Note: The 31M-DHT-15 [1.5kW output] and 32M-DHT-28 [2.0kW output] capacity servo motors uses a straight plug output receptacle type. The applicable Motor Power Cable should be plugged directly into these connectors.



- Install and mount the servo motor in an environment free of hazardous substances such as flammable fluids or gases, corrosive chemical fluids or gases, water, or direct sunlight.
- Ensure that the servo motor will not be subject to splashes of cooling fluid, oil, or residual metal chips from the machinery.
- Do not subject the cables to large amounts of stress. Including tension, bending, or twisting.
- The motor specifications are valid for cable lengths <20m, contact DMM Technology Corp. if cables need to be longer.
- Do not perform unauthorized modifications to the servo motor or cables
- Ensure that the servo motor is not in direct contact with any heat sensitive objects. The servo motor may generate large amounts of heat after prolonged use.
- In general, the servo motor should be installed and mounted in a well ventilated, low humidity area that will not be subject to significant vibration or shock.

■ Encoder Feedback

For 0.22kW to 0.75kW servo motors:

Part Number	Length
CA-9M9F-10	10ft (3.05m)
CA-9M9F-15	15ft (4.57m)
CA-9M9F-25	25ft (7.62m)

*: Custom lengths available. Contact DMM Technology Corp. for details.

For 1.5kW to 2.0kW servo motors:

Part Number	Length
CA-ECRL-10	10ft (3.05m)
CA-ECRL-15	15ft (4.57m)
CA-ECRL-25	25ft (7.62m)

*: Custom lengths available. Contact DMM Technology Corp. for details.

- Servo Motor Power Cable: For 0.22kW to 0.75kW servo motors

The motor power cables should be extended using insulated electrical/industrial wires according to the following selection. Separate this cable from the encoder feedback cable or any other cable used for I/O to avoid noise or disruptions in communication. Do not bundle the motor power cable in the same duct or bracket with any other cables.

	Part Number	Length
Premium Type (With Shielding) 16AWG	CA-MPWR-10P	10ft (3.05m)
	CA-MPWR-15P	15ft (4.57m)
	CA-MPWR-25P	25ft (7.62m)
	CA-MPWR-35P	35ft (10.67m)

*: Custom lengths available. Contact DMM Technology Corp. for details.

- Servo Motor Power Cable: For 1.5kW to 2.0kW servo motors

The 1.5kW and 2.0kW servo motors uses circular L-shaped plugs. The motor power cables should be extended using insulated electrical/industrial wires according to the following selection. Separate this cable from the encoder feedback cable or any other cable used for I/O to avoid noise or disruptions in communication. Do not bundle the motor power cable in the same duct or bracket with any other cables.

	Part Number	Length
Premium Type (With Shielding) 12AWG	CA-MPWR-T10P	10ft (3.05m)
	CA-MPWR-T15P	15ft (4.57m)
	CA-MPWR-T25P	25ft (7.62m)
	CA-MPWR-T35P	35ft (10.67m)

*: Custom lengths available. Contact DMM Technology Corp. for details.